

A-A (1:5)

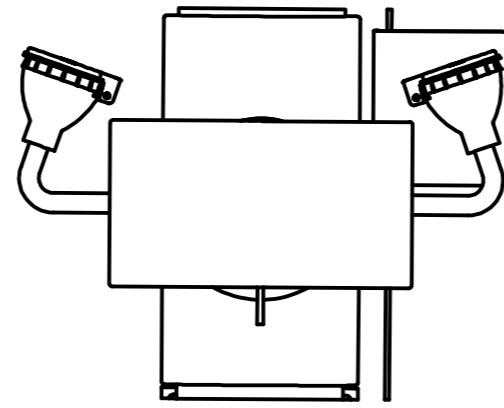

C (1:2)

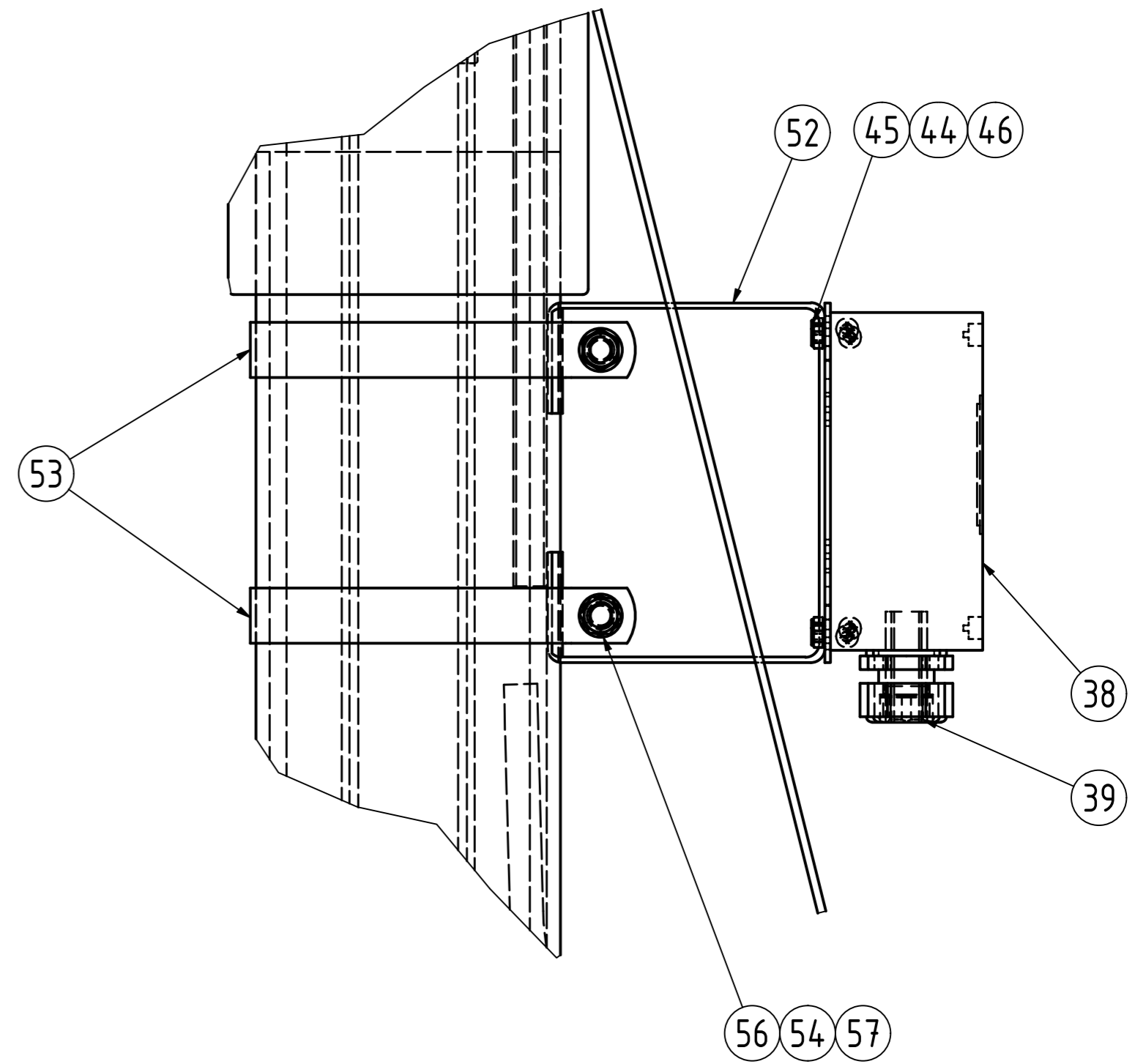

A2

This drawing must not without our permission be copied, imparted to third parties or used in any way for reproduction, modification or other purposes. All rights reserved. Detta ritning får inte utan tillstånd kopieras, modifieras eller på annat sätt användas. Överträdelse beivras med stöd av gällande lag.

2	57	Bult/Bolt	0057-825	M8x25
4	56	Bricka/washer	5149-8	M8
2	54	Mutter/Nut	0368-8	M8, Lock
2	53	Klamma/Clamp	820872	110 mm
1	52	Dosfäste/Bracket	820887	
1	51	Stomme, värmeisol.	8223674-0	
4	46	Skruv/Screw	0046-412	M4x12
4	45	Mutter/Nut	0368-4	M4, Lock
4	44	Bricka/Washer	5149-4	M4
1	39	Anslutningssats/connection Kit	820342	
1	38	Termostat/Thermostat, Raychem AT-TS-13	820557	

Ant.	Det.-nr	Dimension/Benämning	Material/Ritn.nr/Art nr	Anm.
A				
Ritningen MAKULERAS efter avslutat projekt		Proj. nr.	Datum	Sign.
		Konstr. FB	Kontr.	Godk.
		Skala 1:8	Revision 1	Ersatt av
		Nöd/-ögonusch 26 + 150l/min SS2343	Filnamn 8223674	Dat. 2018-08-24
		GIA Premix	Ritn.-nr 8223674	

Nr.	Ant.	Ändring och/eller medd.-nr	Datum	Inf.	Godk.