

C-C (1 : 2)

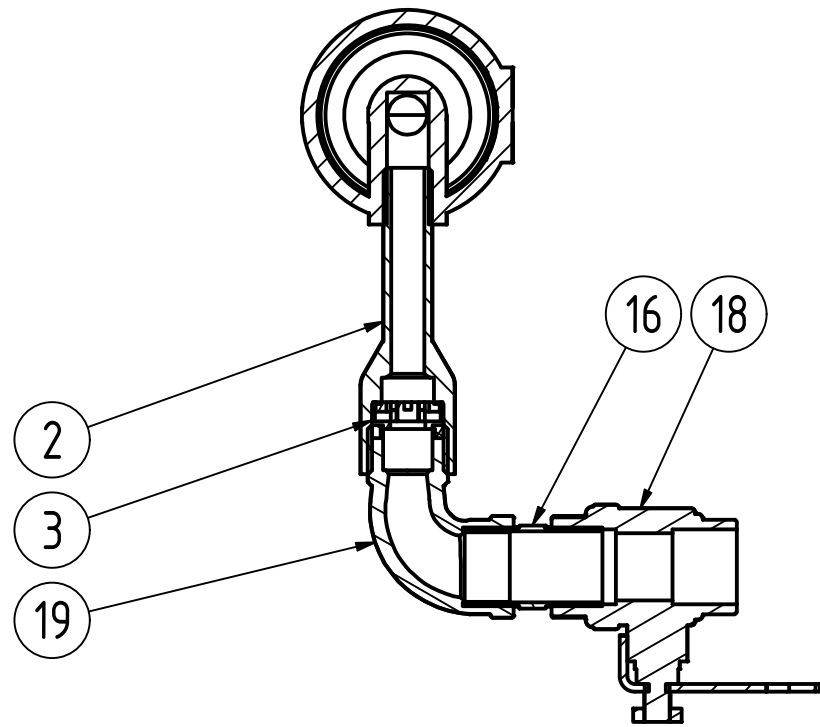

B-B (1 : 4)

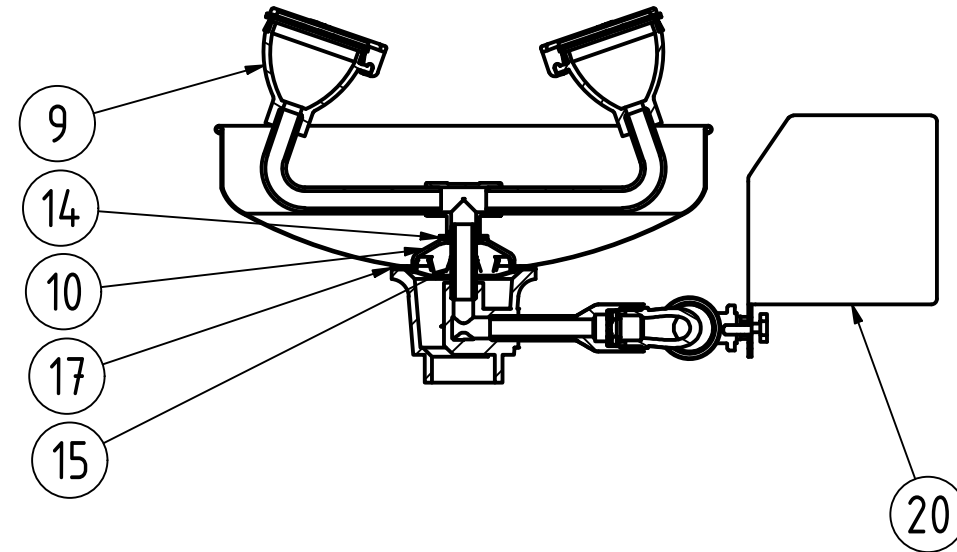

This drawing must not without our permission be copied, imparted to third party or otherwise unauthorizedly used. Contravenition will be prosecuted.
 Denna ritning får ej utan vårt medgivande kopieras, delgivas annan eller eljest obehörigen användas. Överträdelse beivras med stöd av gällande lag.

1	20	Tryckplatta/Pressure plate	821190	1.4301
1	19	Vinkel/Elbow connector	820758	DN15 inv/utv, SS2343
1	18	Ventil DN15	821228	DN15, SS
1	17	Packning, gummi/Gasket, rubber	820124	
1	16	Sexkantsnippel/Nipple	820211	DN15 , SS2343
1	15	Nippelrör/Nipple	820214	1.4404
1	14	Nylonbussning/Nylon bushing	820807	
1	10	Sil/Strainer	820341	
1	9	Spolhus, 26 l.	820502	
1	7	Skål utan lock/Bowl w/o lid	820187	
1	3	Flödes reg./Flow regulator	820691	
1	2	Rör/Pipe	820692	
1	1	Konsol/Bracket	820808	
Ant.	Det.-nr	Dimension/Benämning	Material/Ritn.nr/Art nr	Anm.
A				

Ritningen MAKULERAS efter avslutat projekt		Proj. nr.	Datum	Sign.	Beräknad vikt	Vägd vikt
Konstr.	Ritad	Kontr.	Godk.	Skala	Revision	Ersatt av
	FB			1:4	1	
 GIA Premix Ögon- /ansiktsdusch 26 lit/min				Filnamn 8223567	Dat. 2018-08-17	Ritn.-nr 8223567

Nr	Ant.	Ändring och/eller medd.-nr	Datum	Inf.	Godk.