

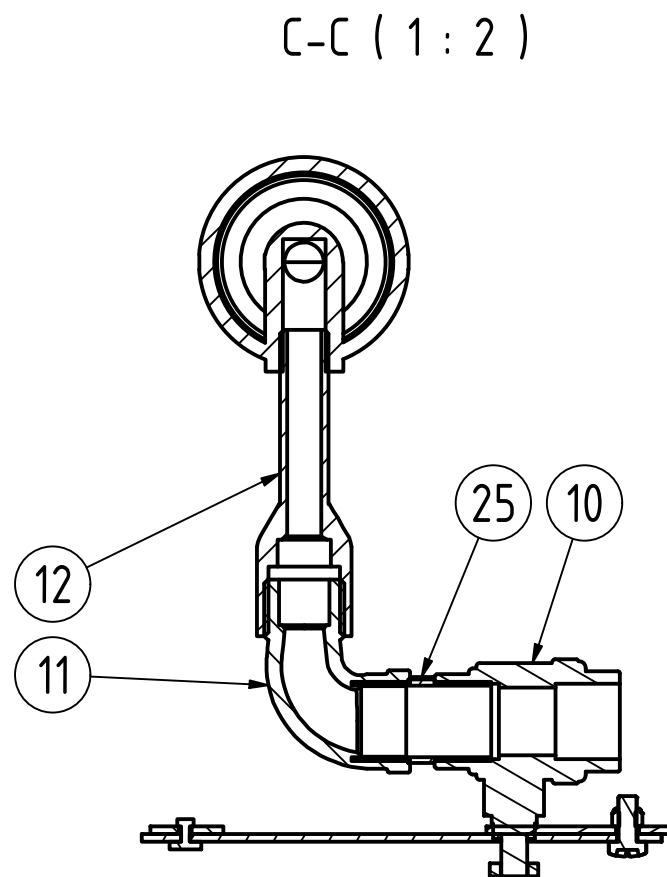

This drawing must not without our permission be copied, imparted to third party or otherwise unauthorizedly used. Contravenition will be prosecuted.  
Denna ritning får ej utan vårt medgivande kopieras, delgivas annan eller eljest obehörigen användas. Överträdelse beivras med stöd av gällande lag.

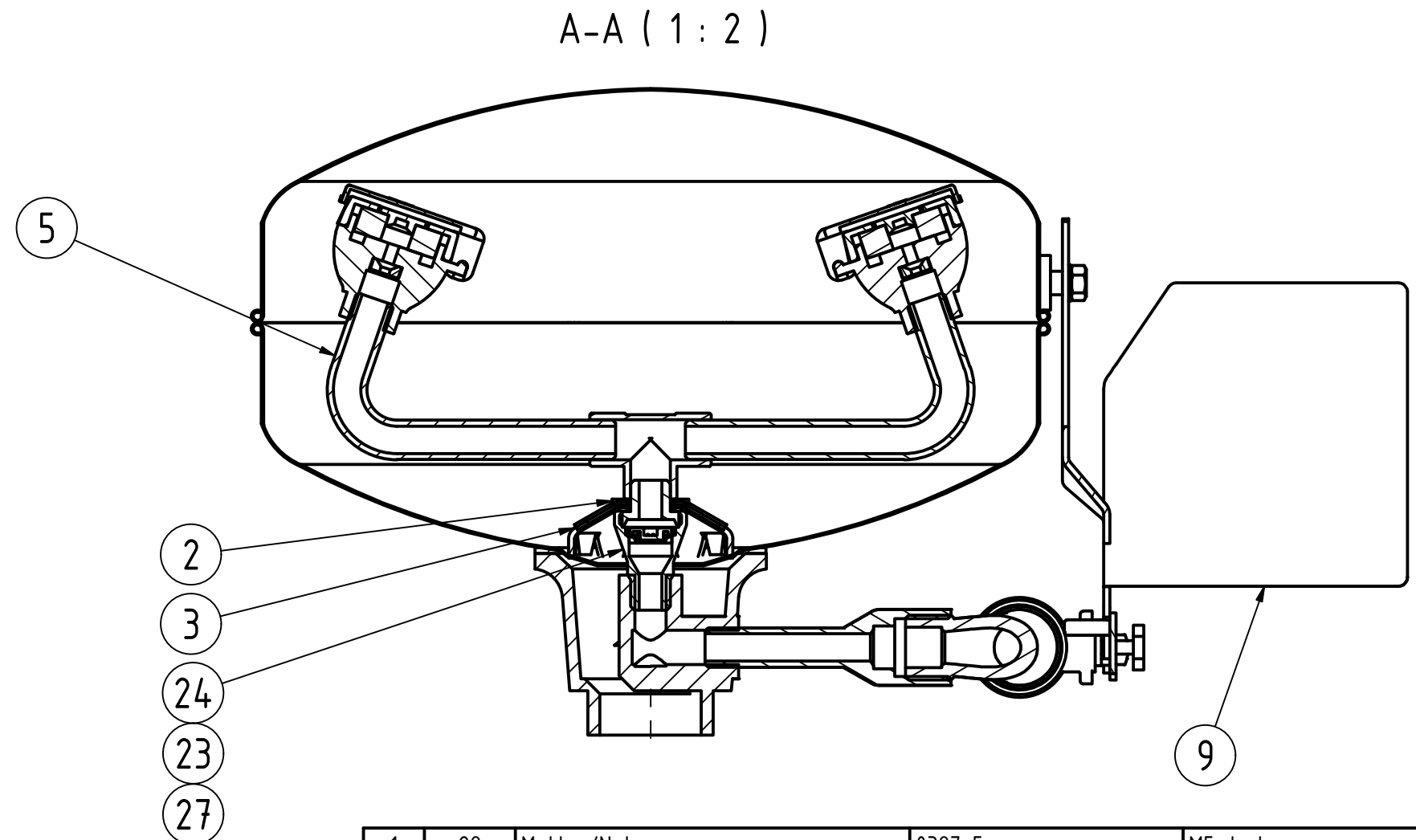
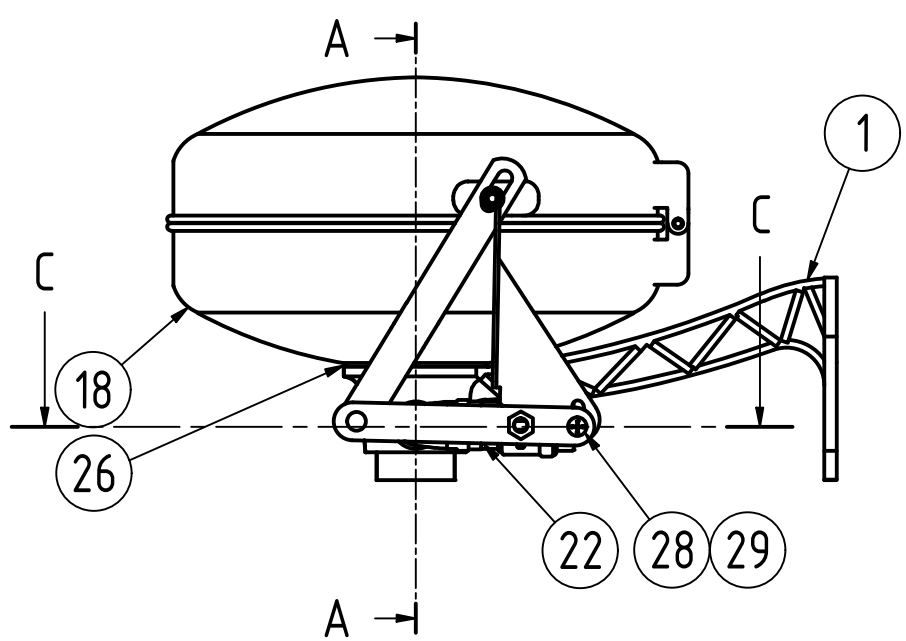

1	29	Mutter/Nut	0397-5	M5, lock
1	28	Skruv/Screw	0293-512	M5x12
1	27	Flödesreg./Flow regulator	820972	10 l/min
1	26	Packning, gummi/Gasket, rubber	820124	
1	25	Sexkantsnippel/Nipple	820211	DN15 , SS2343
1	24	Nippel, Flödesreglering	820729	
1	23	Nippel, Flödesreglering	820728	
1	22	Länkarm/Drop arm	820188	
1	18	Skål med lock/Bowl with lid	820189	
1	12	Rör/Pipe	820692	
1	11	Vinkel/Elbow connector	820758	DN15 inv/utv, SS2343
1	10	Ventil DN15	821228	DN15, SS
1	9	Tryckplatta/Pressure plate	821190	1.4301
1	5	Spolhus, 10l/min	820701	
1	3	Sil/Strainer	820341	
1	2	Nylonbussning/Nylon bushing	820807	
1	1	Konsol/Bracket	820808	
Ant.	Det.-nr	Dimension/Benämning	Material/Ritn.nr/Art nr	Anm.

Ritningen MAKULERAS efter avslutat projekt		Proj. nr.	Datum	Sign.	Beräknad vikt	Vägd vikt
Konstr.	Rifad	Kontr.	Godk.	Skala	Revision	Ersatt av
	FB			1:4	1	
 GIA Premix Ogondusch 10 lit/min					Filnamn	Dat.
					8223563	2018-08-16
					Ritn.-nr	
					8223563	

Nr	Ant.	Ändring och/eller medd.-nr	Datum	Inf.	Godk.