

This drawing must not without our permission be copied, imparted to third party or otherwise unauthorizedly used. Contravention will be prosecuted.
Denna ritning får ej utan vårt medgivande kopieras, delgivas annan eller eljest obehörigen användas. Överträdelse beivras med stöd av gällande lag.

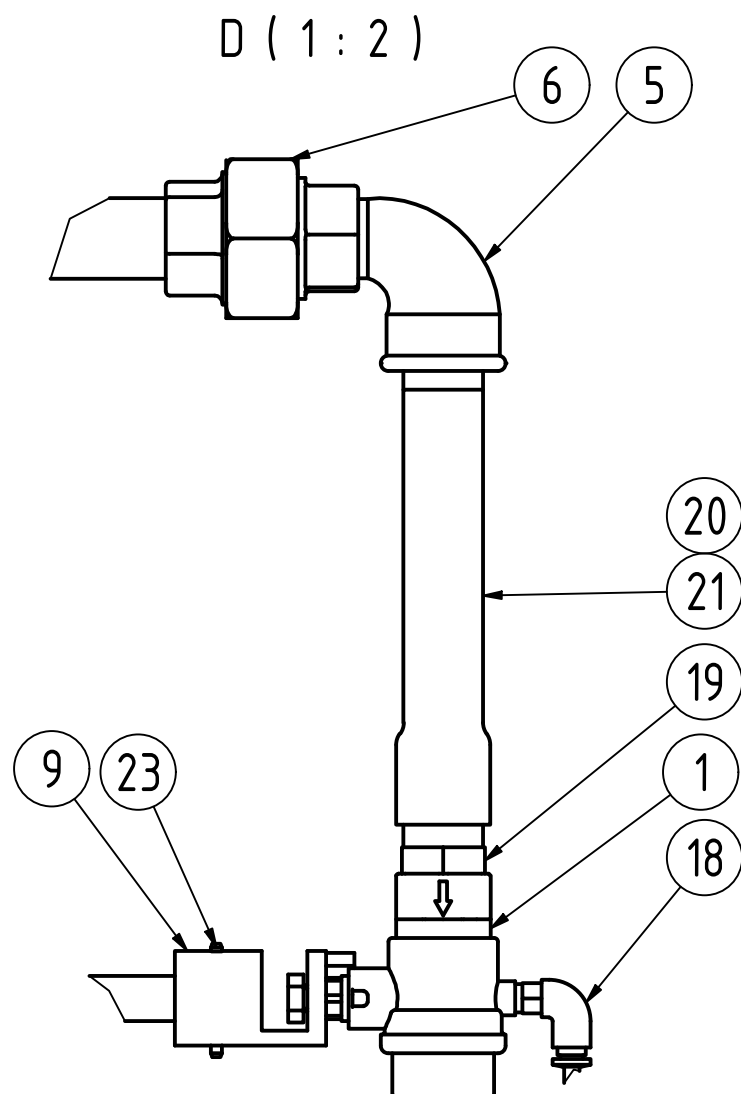
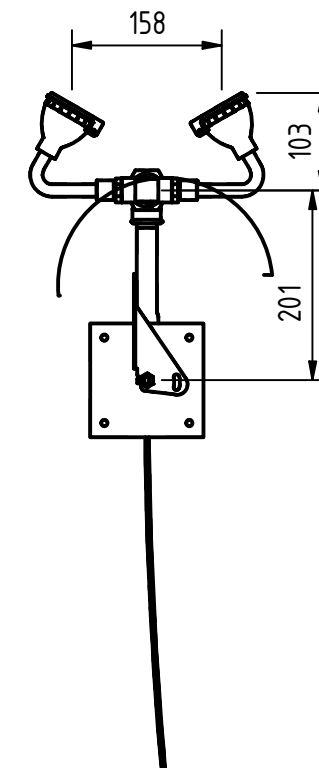
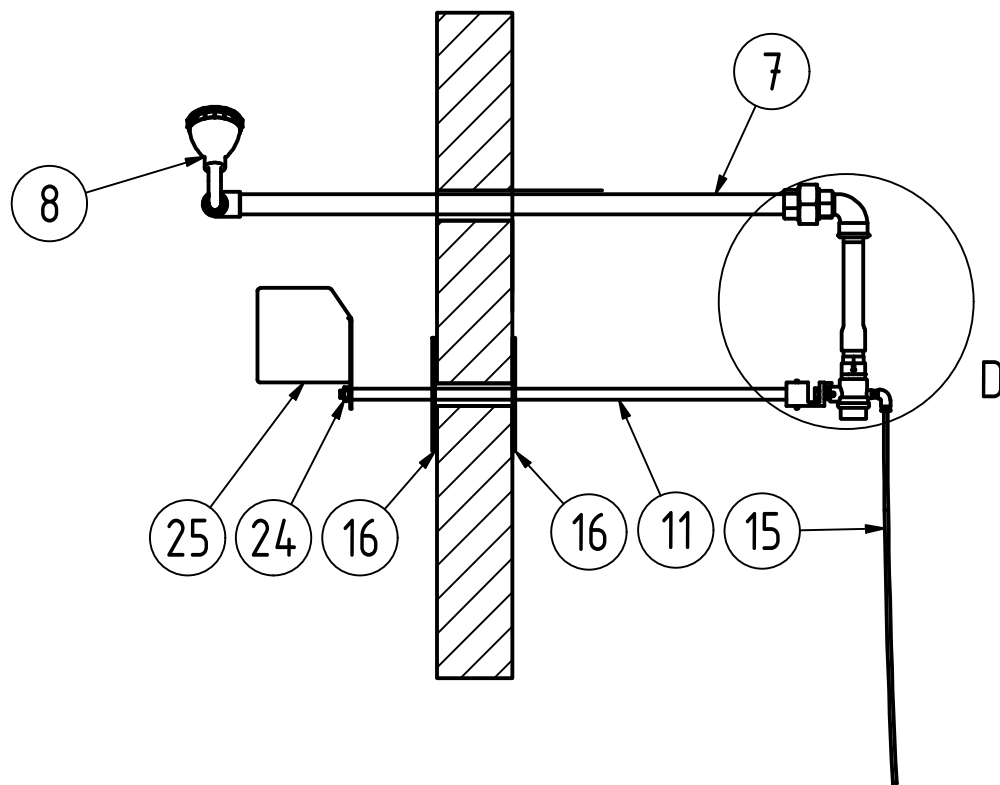

1	25	Tryckplatta/Pressure plate	821190	1.4301
1	24	Mutter/Nut	0368-8	M8, Lock
1	23	Fjädrande rörpinne/Pin	0475-330	3x30mm
1	21	Rör/Pipe	820693	DN15x130mm kromat/chrome
1	20	Flödes reg./Flow regulator	820691	
1	19	Sexkantsnippel/Nipple	820211	DN15 , SS2343
1	18	Anslutning/connector	820377	R1/8" rak, 4mm slang
2	16	Täckbricka/Cover plate	820656	
1	15	Slang, plast/Hose, plastic	820375	4mm L=1000
1	11	Stång/Bar	820164	
1	9	Mellanstycke ventil/Middlepart valve	820150	
1	8	Spolhus/Flushing House	820703	26l/min
1	7	Rör/Pipe	820010	DN15 galv L=610
1	6	Koppling/Coupling	820037	DN15 galv
1	5	Vinkel/Elbow connector	820041	DN15 inv/utv
1	1	Ventil/Valve DN15	820370	
Ant.	Det.-nr	Dimension/Benämning	Material/Ritn.nr/Art nr	Anm.

Ritningen MAKULERAS efter avslutat projekt		Proj. nr.	Datum	Sign.	Beräknad vikt	Vägd vikt
Konstr.	Ritad	Kontr.	Godk.	Skala	Revision	Ersatt av
	FB			1:8	1	
Ögon-/ansiktsdusch 26 l/min, fryssäker					Filnamn	Dat.
					8223552	2018-08-16
					Ritn.-nr	

Nr	Ant.	Ändring och/eller medd.-nr	Datum	Inf.	Godk.